

Note:  
 Tolleranze generali ±0.10  
 Togliere bave e spigoli vivi  
 Assieme di progetto

NORME DI RIFERIMENTO Referential norms	
TECNICHE Technical	
FILETTI Threads	GAS UNI ISO 228/1
COMPOSIZIONE Composition	
RUGOSITA' Machining parameter	UNI 3963

sez. A-A

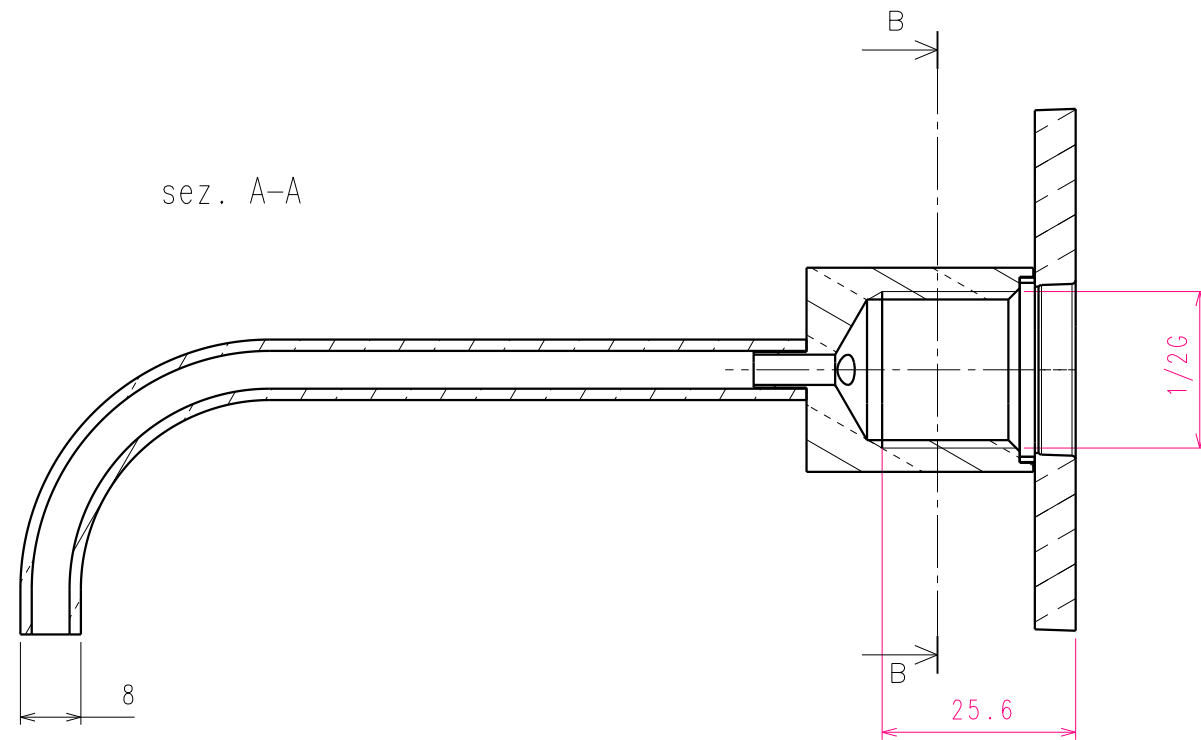

sez. B-B

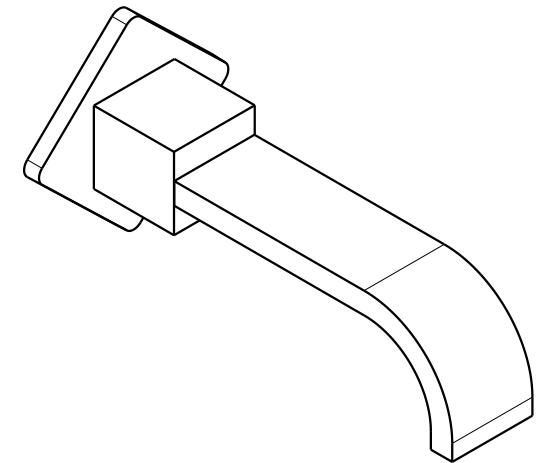
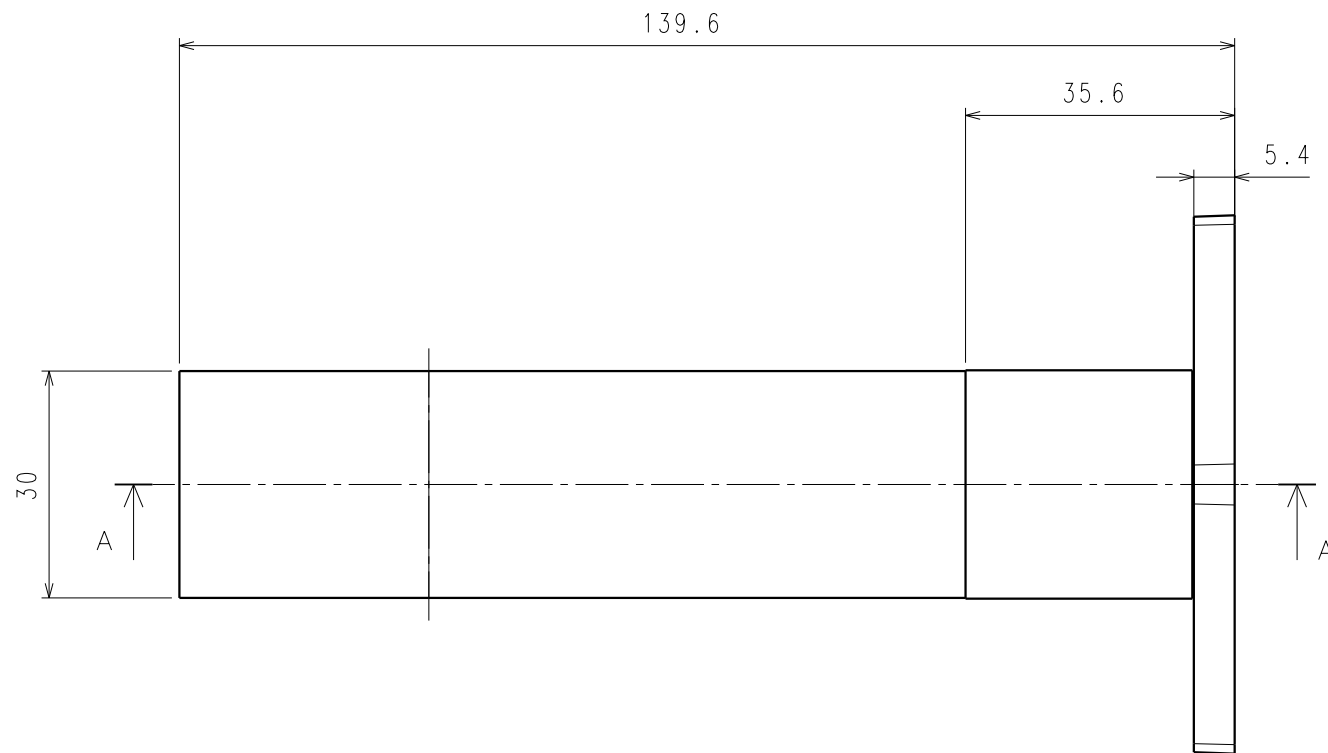
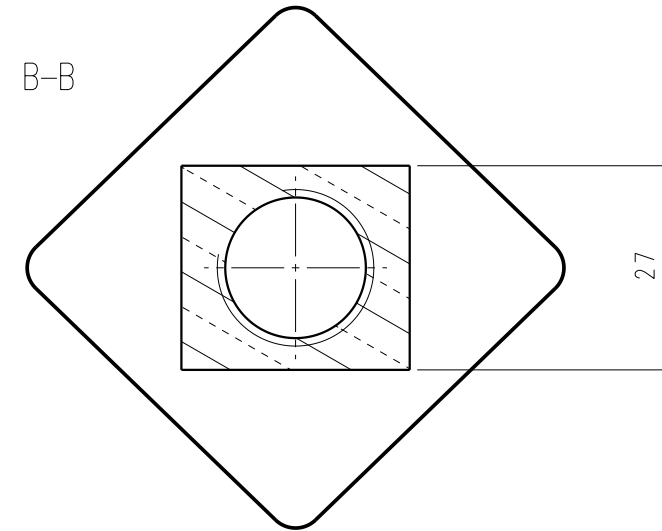

La Torre SpA  
 Rubinetteria dal 1960  
 28045 INVORIO  
 Fraz. Talonno / NO - Italy  
 Via Altovergante, 33  
 Tel. 0322/255391 r.o.  
 Fax. 0322/255442  
 www.latorre-spa.it  
 E-mail marco@latorre-spa.it  
 E-mail andrea@latorre-spa.it

REV.	0	PRIMA EMISSIONE First issue	ANDREA COGO	02-11-2006
DESCRIZIONE - Description	DESCRIZIONE - Description		ESEGUITO - Prepared	DATA - date
COD. INTERNO Internal code	PROGETTO_19144 SOUTHCAPE	UNIFORMITÀ General tolerance	UNI 22768-1:1996	FINITURA SUPERFICI Surface finish
DESCRIZIONE Description	PROGETTO_19144 SOUTHCAPE			
MATERIALE Material	VARIO	TRATTAMENTO Treatment	-	
PESO GR Weight gr	361,8	SCALA Scale	1:1	U.M. U.M.
		mm	FORMATO Format	A3
			TAVOLA Sheet	1/1